



# UNiSYSTEM

TECHNICAL SPECIFICATIONS



**BRITISH OFFSITE IS THE CREATOR OF UNISYSTEM, THE MOST TECHNICALLY ADVANCED, LIGHT GAUGE STEEL PANEL SYSTEM IN THE MARKETPLACE.**

Adaptable to any design vision, UNisystem can be used for housebuilding, mid-rise and high-rise developments, and for the construction of commercial and public buildings.

UNisystem is manufactured at Horizon, our flagship factory in the heart of Essex, which was founded with investment from the Weston Group and designed with Randek UK.

By employing Randek’s state-of-the-art robotics we have quadrupled our production capacity to 110,000 Im – the equivalent of 4,000 homes per year.

Now with two factories in operation – Skyline and Horizon – we can manufacture a complete set of panels for one apartment every 60 minutes.

**CONTENTS**

UNisystem overview	1	UNisystem loadbearing	25
Testing and compliance	4	– UNipanel <sup>LB</sup>	28
Speed of delivery	6	– UNiwall <sup>LB</sup>	32
UNisystem non-loadbearing	9	– Sequencing	34
– UNipanel	12	– Floor and roof options	36
– UNiwall	16	– UNifloor	38
– Sequencing	18	Installation	43
– Comparison to traditional build	20	Memberships and accreditations	44
		Sustainability	48
		Logistics	50
		Where to find us	52



# BOS UNISYSTEM

UNISYSTEM IS A HIGH-PERFORMANCE, 2D PANELISED SYSTEM THAT DELIVERS FUNCTIONING AND OCCUPIABLE SPACES FASTER. TECHNICALLY ADVANCED AND PROVEN IT MEETS ALL NECESSARY BUILDING STANDARDS AND REGULATIONS, AND IS MANUFACTURED WITH EXACTING PRECISION TO FULLY ALIGN WITH YOUR DESIGN SPECIFICATIONS.

Working in close collaboration with your design team, British Offsite will bring your vision to life, combining UNisystem (non-loadbearing) products with your steel frame or reinforced concrete structure, or utilising UNisystem<sup>LB</sup> (loadbearing) to create self-supporting superstructures.

With light gauge steel at its core, UNisystem delivers the strength and durability needed for schools, student accommodation, hospitals, commercial buildings and residential developments. At the same time it delivers major cost efficiencies, generated by our streamlined and automated manufacturing processes.

Quality checked at every turn, UNisystem and UNisystem<sup>LB</sup> are manufactured to a consistently high standard and combine the work of up to five trades in one panel. With multiple processes completed offsite, the risks and delays typical of today's construction projects are minimised. UNisystem or UNisystem<sup>LB</sup> can add value to any project.



# HIGH-PERFORMANCE SYSTEM RIGOROUSLY TESTED

ALL COMPONENTS OF UNISYSTEM AND UNISYSTEM<sup>LB</sup> ARE SUBJECT TO RIGOROUS TESTING AND QUALITY CONTROL, TO MAKE SURE EXCELLENT FIRE PROTECTION, THERMAL AND ACCOUSTICS PERFORMANCE ARE MAINTAINED, AND EVERY PANEL ARRIVES ON SITE READY TO INSTALL WITHOUT ISSUE.

# COMPLIANT WITH ALL STANDARDS AND REGULATORY REQUIREMENTS

UNISYSTEM AND UNISYSTEM<sup>LB</sup> HAVE BEEN TESTED AND APPROVED IN ACCORDANCE WITH THE FOLLOWING STANDARDS.

## Structure

BS EN 1991-1 and its sub-parts that cover:

- Densities, self-weight and imposed loads.
- Actions due to fire, snow and thermal actions.
- Loads during execution and accidental actions.
- UNisystem achieved SCI/NHBC Stage 1 System Certification covering structural strength, stability and durability.

## Fire

- EN1365-1:2015 for non-loadbearing panels.
- EN1365-1:2012 for loadbearing panels.

## Acoustic

- BS EN ISO 140-4:1998 for airborne insulation on separating walls.

## Vapour

- U-Value generated in accordance with the Glaser Method, as required by the NationalHouse Building Council.
- U-Values generated with and without rainscreen slabs at both 50mm and 100mm widths.

Airtightness and acoustics are tested post-installation, in line with British Standards, ensuring every home, health, education and commercial space built with UNisystem meets or exceeds the required levels.

Fire, thermal and weathersealing tests have been carried out on the full UNisystem product range and full compliance with British Standards and UK building regulations has been achieved.

## NEW BUILDING REGULATIONS 2023

New UK building regulations in 2023 place further requirements on designers and developers to reduce carbon emissions during the construction and in the operation of new buildings.

With a “fabric first” approach to reducing energy consumption, British Offsite has built energy efficiency, as well as safety features, into all components of UNisystem, so designers and developers can readily achieve compliance and fulfil their build plan.

British Offsite is strengthening carbon reduction and energy efficiency measures at every stage of our value chain – from product development through to the operation of buildings – to achieve our goal of being carbon net zero.

Our customers and end-customers can be confident when UNisystem or UNisystem<sup>LB</sup> are used, they are purchasing a safe, energy efficient, durable and high performance building that is cost effective to run.

# FAST MANUFACTURING AND CONSTRUCTION

## 120 DAYS

BRITISH OFFSITE CAN CONVERT A TRADITIONAL CONSTRUCTION PROJECT TO A HYBRID MANUFACTURING AND CONSTRUCTION PROJECT AND DELIVER TO SITE IN AS LITTLE AS 120 DAYS.

## 5

THE WORK OF UP TO FIVE TRADES ARE CONSOLIDATED IN THE MANUFACTURE OF ONE UNISYSTEM PANEL, SAVING TIME AND RESOURCES IN THE CONSTRUCTION PROCESS AS WELL AS SPACE ON SITE.

## 15 MINUTES

ONE UNIPANEL COMPLETE WITH WINDOWS, DOORS, INSULATION AND FIRE STOPPING CAN BE PRODUCED BY THE HORIZON FACTORY EVERY 15 MINUTES.

## 60 MINUTES

FOUR UNIPANELS FOR A TYPICAL APARTMENT CAN BE INSTALLED ON SITE IN ONE HOUR.

## 30%



CHOOSING TO MANUFACTURE YOUR PANELS WITH BRITISH OFFSITE CAN IMPROVE FIRST FORK IN THE GROUND TO FIRST KEYS HANDOVER TIME BY UP TO 30%.



Edinburgh Way, Harlow  
CGI is indicative only



# UNiSYSTEM NON-LOADBEARING

				
UNiPANEL				
UNiWALL				

# UNISYSTEM NON-LOADBEARING

THE UNISYSTEM NON-LOADBEARING COMPONENTS ARE UNIPANEL (EXTERNAL WALLS) AND UNIWALL (INTERNAL WALLS). THEY OPERATE AS INFILL PANELS, WORKING IN CONJUNCTION WITH A LOADBEARING STEEL OR REINFORCED CONCRETE STRUCTURE THAT DELIVERS VERTICAL LOAD TRANSMISSION AND FLOORING.

UNipanel and UNiwall light gauge steel frames are supplied with internal and external sheathing boards and are filled with insulation that provides thermal, acoustic and fire performance.

Each panel is manufactured using standard materials and assembly processes, but can be adapted to specific structural, thermal, acoustic and fire requirements, calculated on a site-specific basis. External wall insulation, external cavity barriers, external DPC and internal battens can all be altered to meet specific needs.

Panels can be manufactured to a maximum height of 3.2 metres and a maximum length of 8.4 metres. Project requirements outside of these parameters can be assessed on a project specific basis.

As the load-bearing element of the building is taken by the steel or reinforced concrete frame, UNipanel and UNiwall can be used for any height of building, providing the multiple benefits of offsite construction including lower overall on-site build time.

When a reinforced concrete frame is used, edge shuttering for the floor above is incorporated into the head of UNipanel and UNiwall, eliminating any issues with tolerance to the underside of the concrete floor or beam.

Deflection is accommodated via deflection joints built into the head of the panels, which are fixed to avoid movement during construction and then released after the concrete has reached full strength to allow for movement.

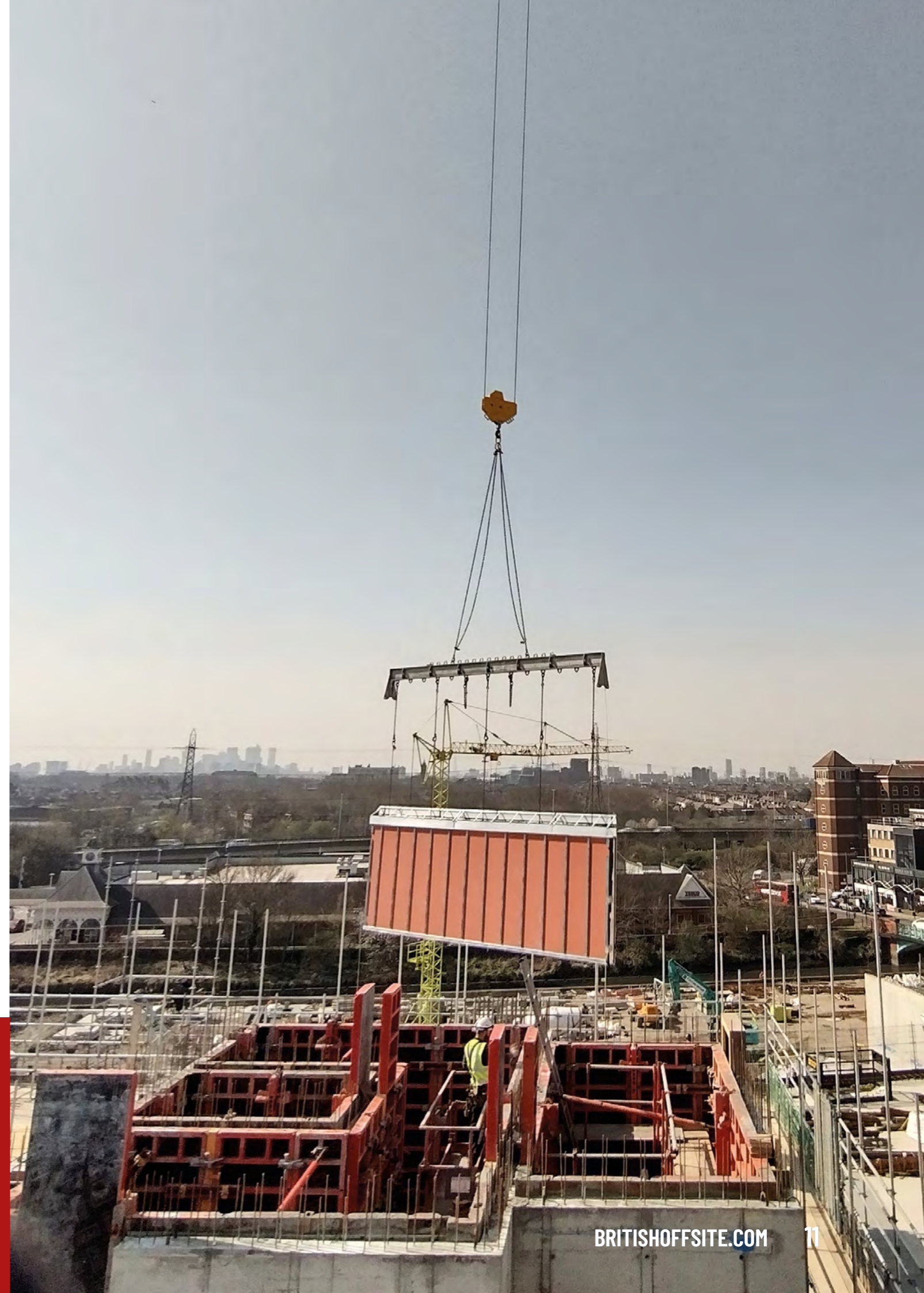

UNIPANEL

8.4m

MAXIMUM LENGTH

3.2m

MAXIMUM HEIGHT



UNIPANEL IS A WEATHERPROOF AND AIRTIGHT EXTERNAL PANEL, ADAPTABLE FOR EVERY ARCHITECTURAL NEED, ACROSS MID-RISE AND HIGH-RISE PROJECTS.

## UNIPANEL NON-LOADBEARING

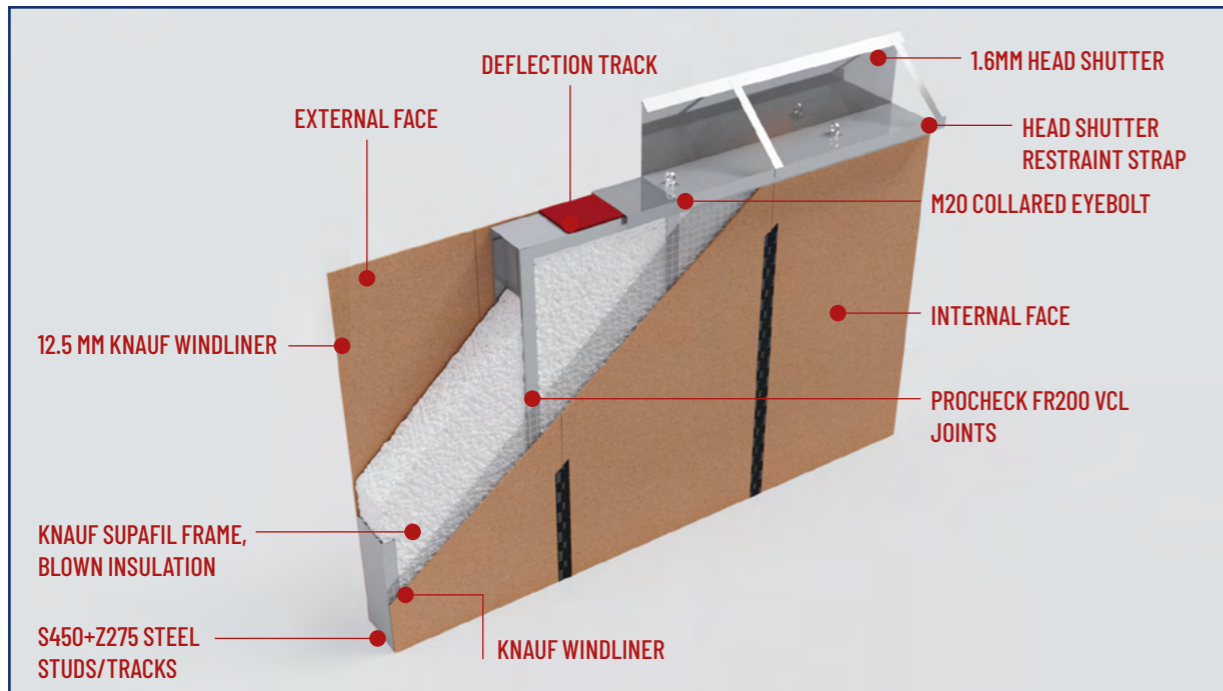

PRODUCT	Fire classification EI*	Airborne Sound Insulation (dB)*	U-Value (W/m2K)*	U-Value (W/m2K) With 50mm Rainscreen Slab	U-Value (W/m2K) With 100mm Rainscreen Slab
UNipanel	60	/	0.29	0.15	0.12

The performance figures provided refer to UNipanel non-loadbearing, excluding any finishes. U-values shown are for brickwork construction.

## UNIPANEL NON-LOADBEARING WITH PRE-INSTALLED WINDOWS AND DOORS



## UNIPANEL NON-LOADBEARING FULL BREAKDOWN

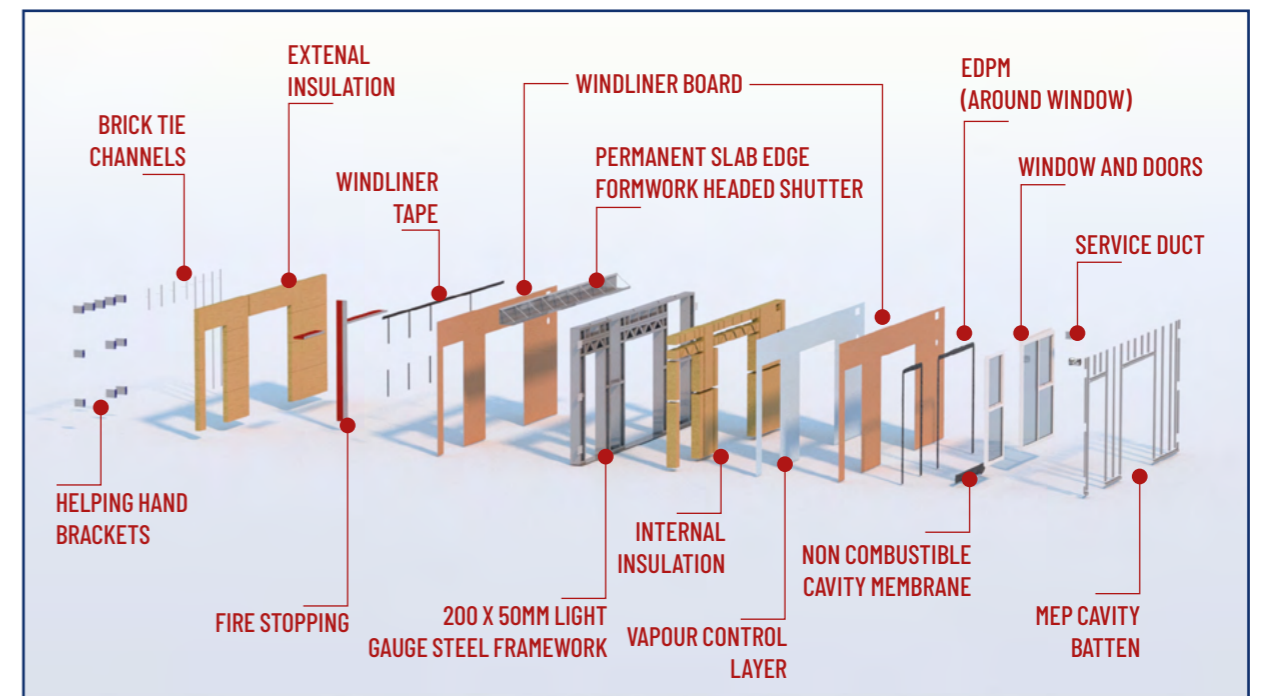



## EXTERNAL FINISHES

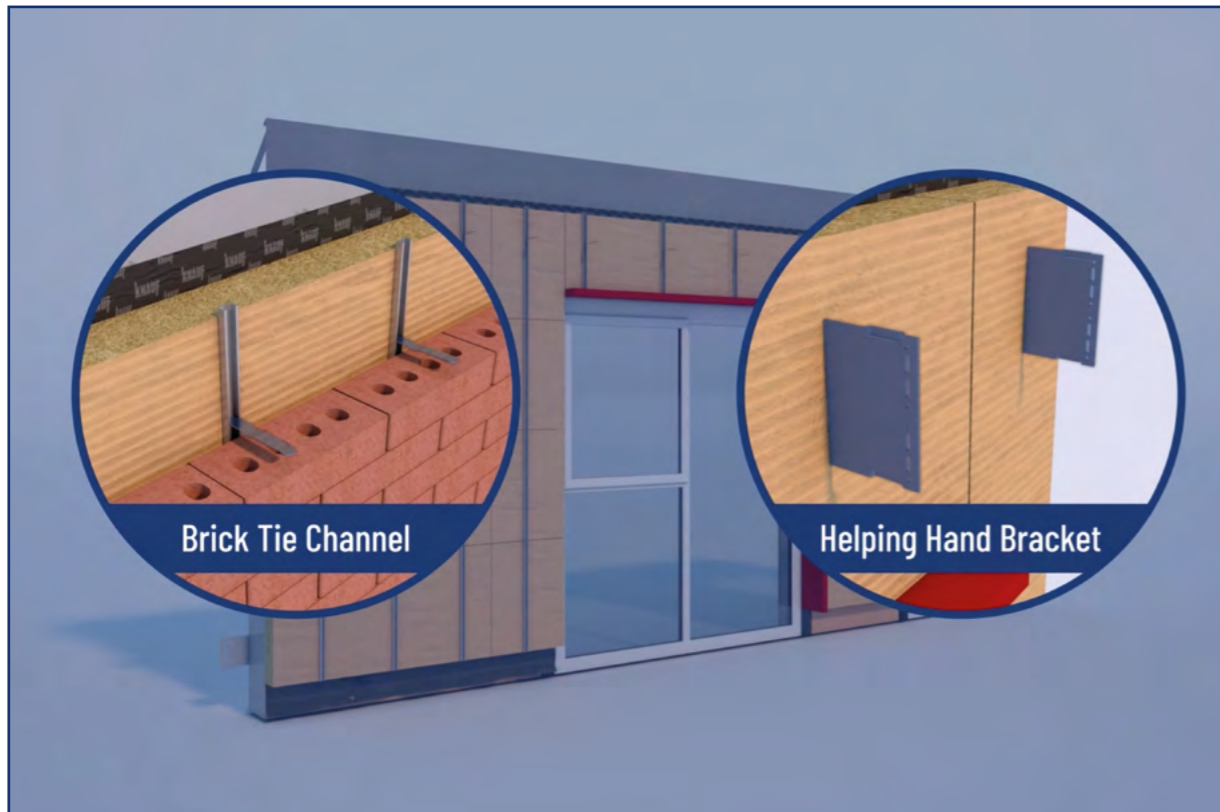

UNIPANEL CAN BE ADAPTED TO ANY DESIGN, WITH FIXINGS APPLIED FOR THE EXTERNAL FINISH OF YOUR CHOICE; BRICK TIES FOR BRICKWORK, HELPING HAND BRACKETS FOR CLADDING OR A BRICK SLIP SYSTEM, OR WITH THE RIGHT MIX OF FIXINGS TO SUPPORT A COMBINATION OF FINISHES.





UNI WALL IS AN INTERNAL COMPARTMENTALISATION PANEL SYSTEM THAT PRODUCES THE HIGHEST STANDARDS OF INTERNAL AIR TIGHTNESS AND ACOUSTICS.

## NON-LOADBEARING

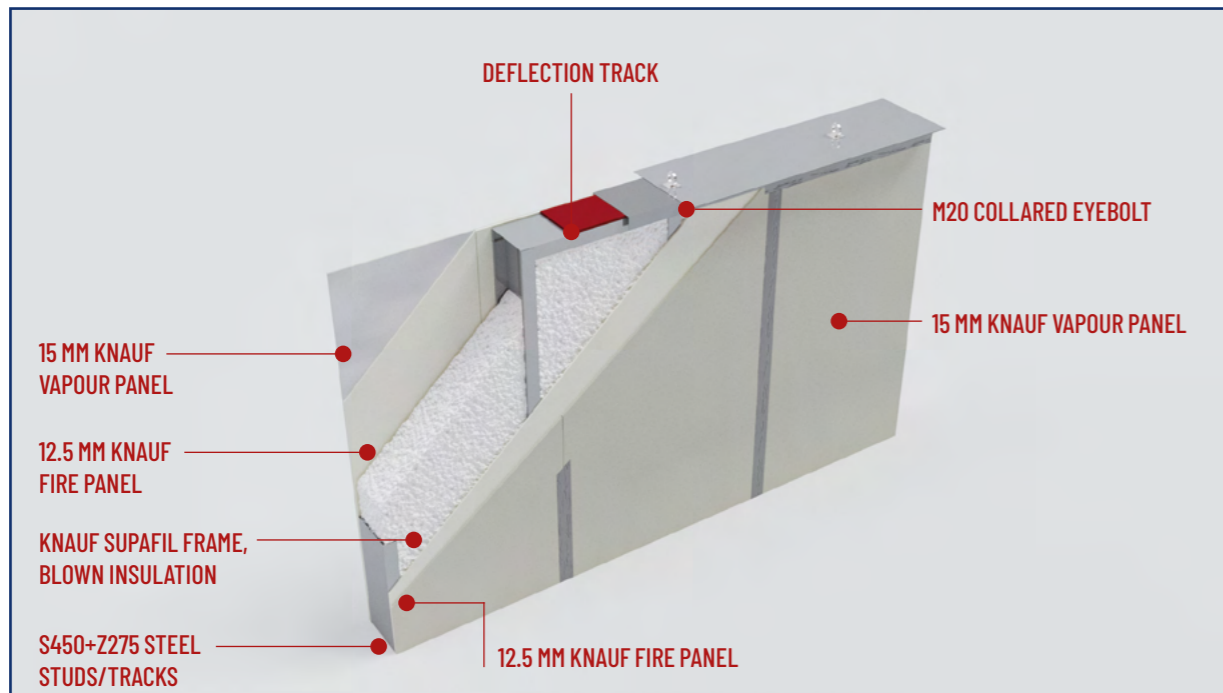

PRODUCT	Fire classification EI*	Airborne Sound Insulation (dB)*	U-Value (W/m2K)*	U-Value (W/m2K) With 50mm Rainscreen Slab	U-Value (W/m2K) With 100mm Rainscreen Slab
UNIwall	120	48	/	/	/

The performance figures provided refer to UNIwall non-loadbearing, excluding any finishes.

## UNI WALL NON-LOADBEARING WITH PRE-CUT DOOR APERTURE



## UNI WALL NON-LOADBEARING BREAKDOWN

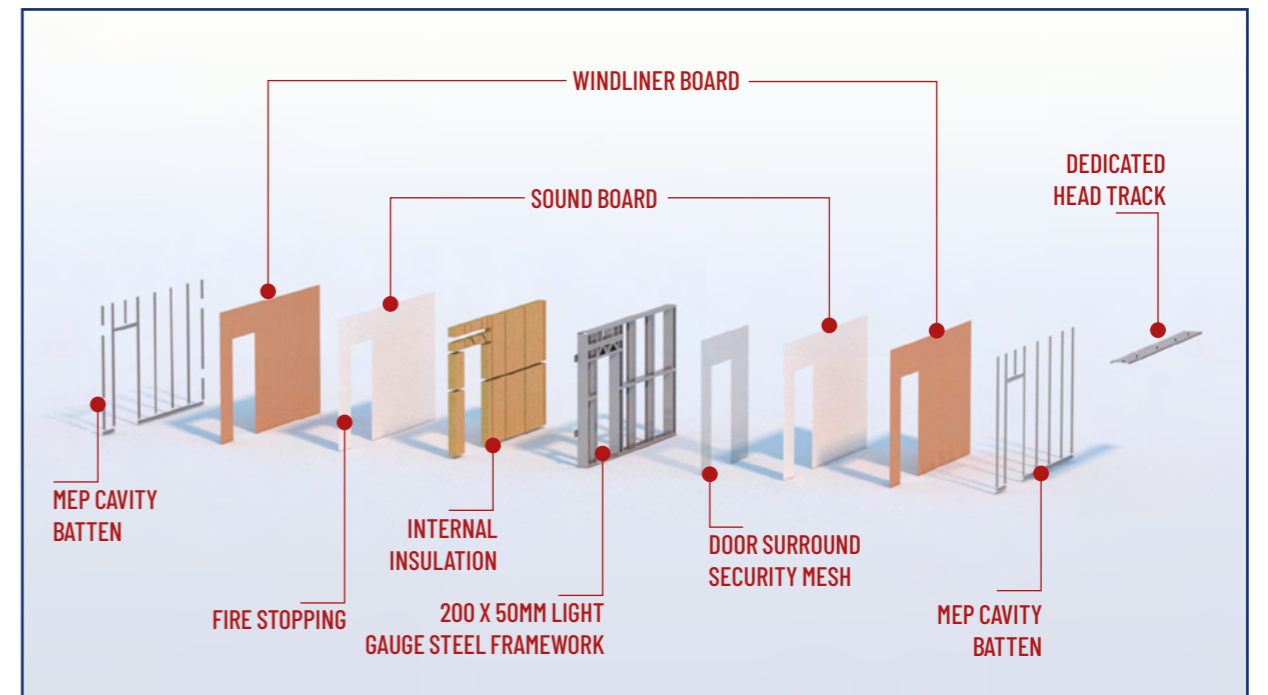

# UNISYSTEM

## NON-LOADBEARING STANDARD SEQUENCING

**STAGE 1:** UNIPANEL EXTERNAL WALLS ARE INSERTED INTO THE STEEL FRAME OR REINFORCED CONCRETE SUPERSTRUCTURE.



**STAGE 3:** FLOOR IS COMPLETED WITH COMPLETE SET OF INTERNAL WALLS TO MATCH FLOOR PLAN SPECIFICATIONS.



**STAGE 2:** UNIWALLS ARE PLACED TO CREATE INTERNAL COMPARTMENTS.



**STAGE 4:** A CAST FLOOR IS LAID OVER UNISYSTEM TO ENABLE THE NEXT STOREY TO BE BUILT.



# UNISYSTEM COMPARISON TO TRADITIONAL BUILD

UNIPANEL AND UNIWALL ARE INSTALLED AS THE CONSTRUCTION OF THE MAIN STRUCTURE PROGRESSES, PROVIDING A CLOSED WATERTIGHT ENVIRONMENT IN A FAR SHORTER TIMEFRAME THAN TRADITIONAL BUILD. THIS ENABLES INTERNAL FIT-OUT TO BEGIN THREE FLOORS BELOW THE OPEN FLOOR.

## British Offsite Process

---

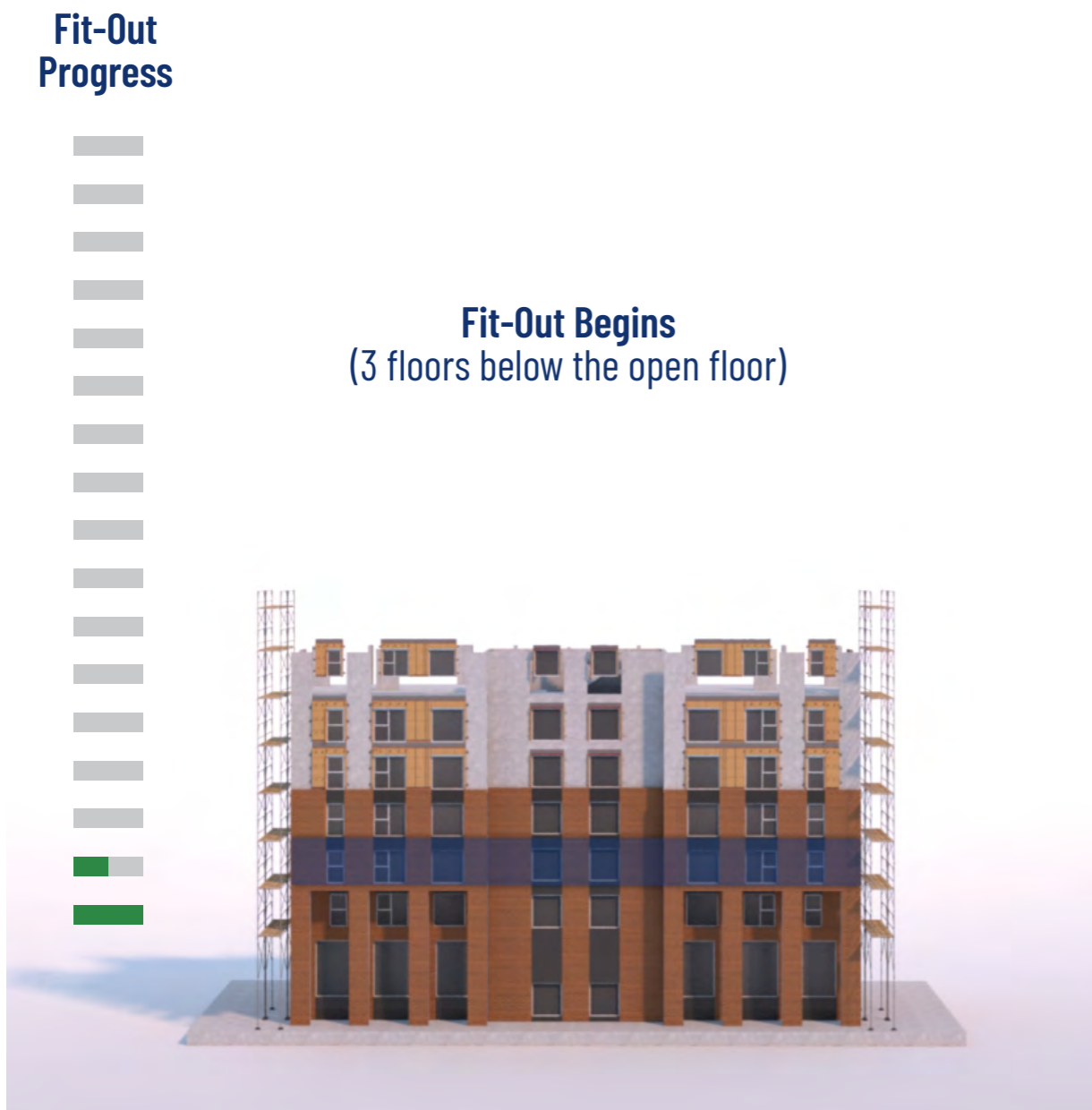

## Traditional Build Process

---



# UNISYSTEM FIT-OUT COMPLETION

THE CONVENTION WITH TRADITIONAL BUILDS IS TO ERECT THE SUPERSTRUCTURE BEFORE WORK BEGINS ON CREATION DRY ENVELOPES, WHICH SIGNIFICANTLY DELAYS COMMENCEMENT OF INTERNAL FIT-OUT.

## British Offsite Process

---

Fit-out up to 30% faster

Fit-Out Progress



## Traditional Build Process

---













Fit-Out Progress





# UNiSYSTEM<sup>LB</sup>

## LOADBEARING

				
UNiPANEL				
UNiWALL				
UNiFLOOR				

CGI is indicative only

# UNISYSTEM<sup>LB</sup> LOADBEARING

UNISYSTEM<sup>LB</sup> COMPONENTS ARE UNIPANEL<sup>LB</sup> (EXTERNAL WALLS), UNIWALL<sup>LB</sup> (INTERNAL WALLS) AND UNIFLOOR. THEY FIT TOGETHER TO CREATE LOW TO MID-RISE BUILDINGS UP TO SIX STOREYS.

As long as the highest floor's finished floor level is 18 metres or less, UNIPANEL<sup>LB</sup> and UNIWALL<sup>LB</sup>, supported by UNIFLOOR or another compatible floor system, can provide the structural requirements of a building. No additional supporting structure is required, though some design and building features may need the inclusion of structural support elements, to provide extra stability.

By eliminating the need for a support structure, UNISYSTEM<sup>LB</sup> saves build time on site, making it a compelling choice for use on small apartment blocks, health and care, education, and student accommodation projects.

The panels are supplied with internal and external sheathing boards and filled with insulation that provides thermal, acoustic and fire performance.

Each panel is manufactured using standard building materials and adapted to the specific structural, thermal, acoustic and fire requirements, designed on a build-by-build basis. External cavity insulation, external cavity fire barriers, external DPC and internal battens can all be altered to meet specific needs.

Panels can be manufactured to a maximum height of 3.2 metres and a maximum length of 8.4 metres. Requirements outside of these parameters or odd shaped panels such as gable ends can be accommodated by using extra panels, and/or custom made panels manufactured in our Skyline factory.



UNIPANEL<sup>LB</sup>

8.4m

MAXIMUM LENGTH

3.2m

MAXIMUM HEIGHT



UNIPANEL<sup>LB</sup> IS ADAPTABLE FOR EVERY ARCHITECTURAL NEED, ACROSS LOW AND MID-RISE PROJECTS.

## UNIPANEL LOADBEARING

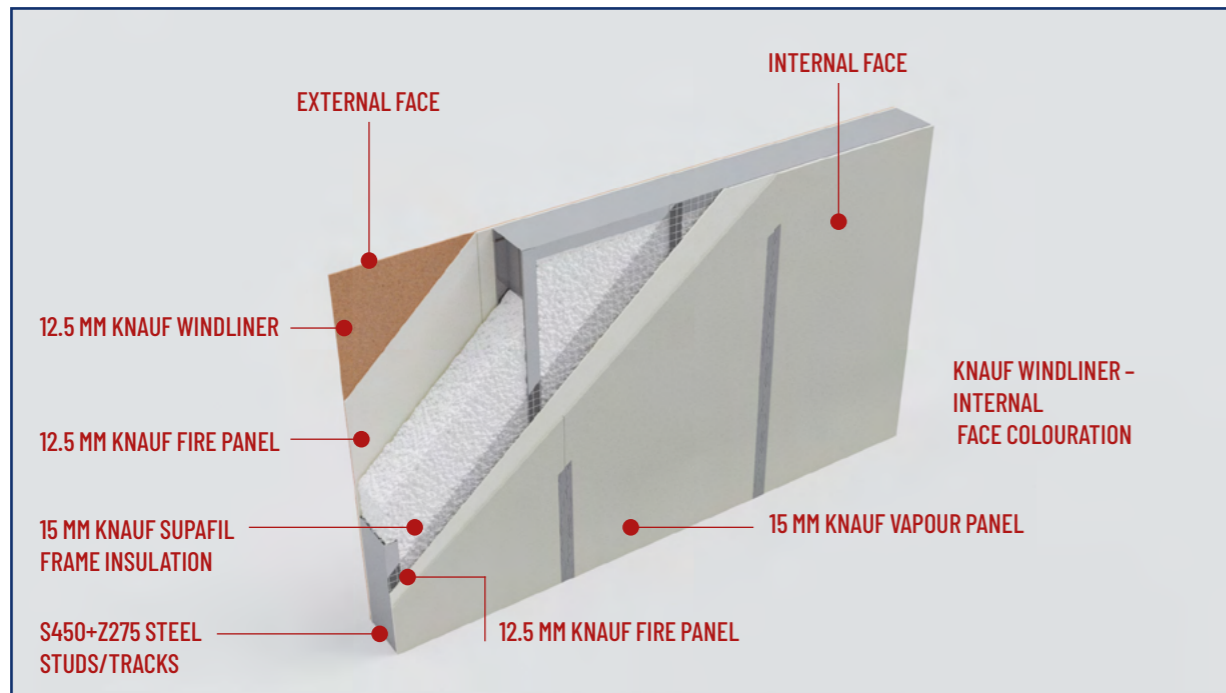

PRODUCT	Fire classification EI*	Airborne Sound Insulation (dB)*	U-Value (W/m2K)*	U-Value (W/m2K)	U-Value (W/m2K)
UNipanel LB	90	/	0.24	With 50mm Rainscreen Slab 0.17	With 100mm Rainscreen Slab 0.13

The performance figures provided refer to UNipanel loadbearing, excluding any finishes. U-values shown are for brickwork construction.

## UNIPANEL LOADBEARING WITH PRE-INSTALLED WINDOWS & DOORS



## UNIPANEL LOADBEARING FULL BREAKDOWN

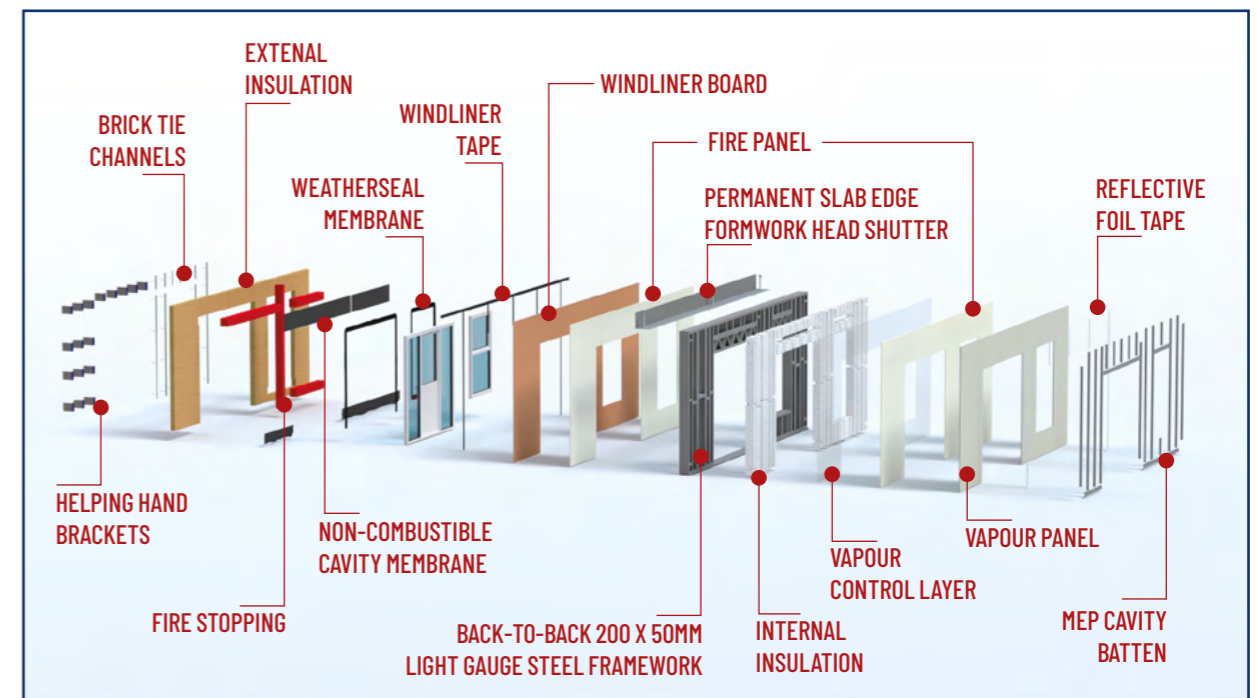



## EXTERNAL FINISHES

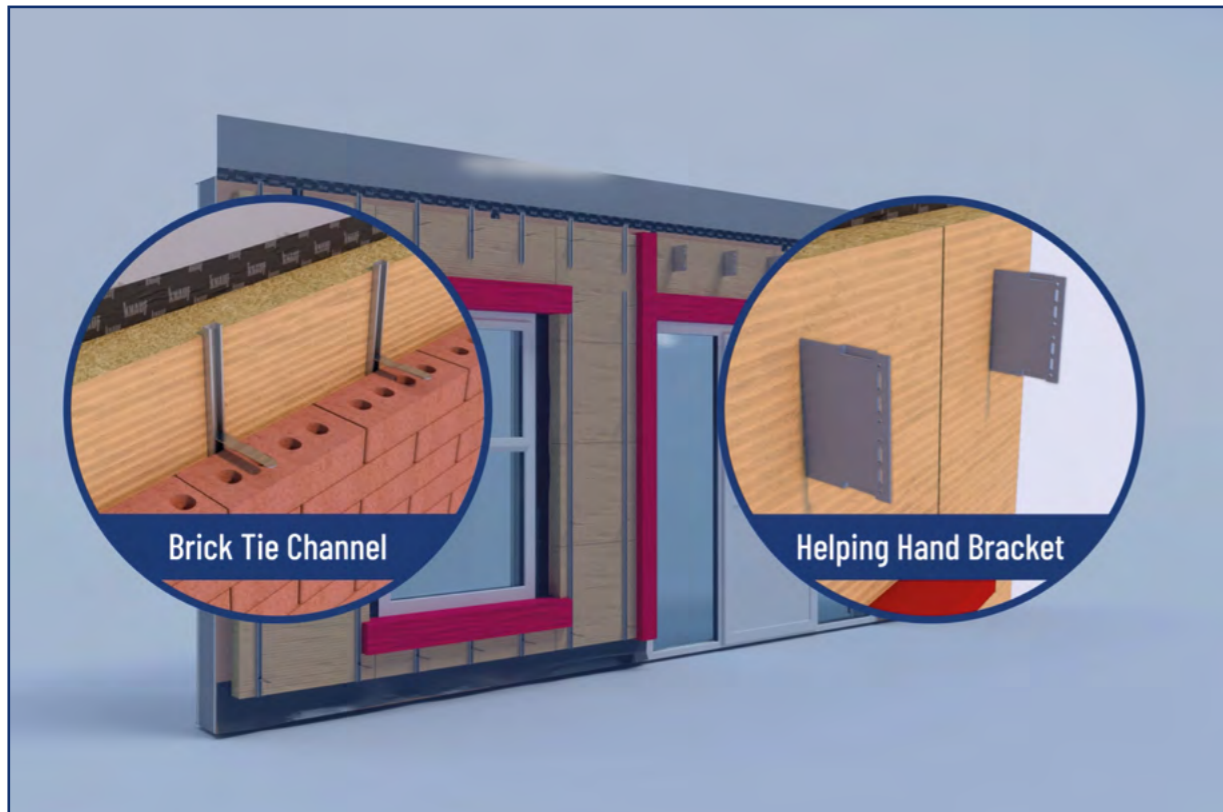

UNipanel<sup>LB</sup> comes complete with the appropriate fixings for your choice of external finish. Every choice can be accommodated, whether you need brick ties for brickwork, helping hand brackets for cladding or a brick slip system, or fixings for a combination of finishes.

Manor Lane, Feltham  
CGI is indicative only





UNI WALL<sup>LB</sup> IS AN INTERNAL COMPARTMENTALISATION PANEL SYSTEM THAT PRODUCES THE HIGHEST STANDARDS OF AIR TIGHTNESS AND ACOUSTICS.

## UNI WALL LOADBEARING

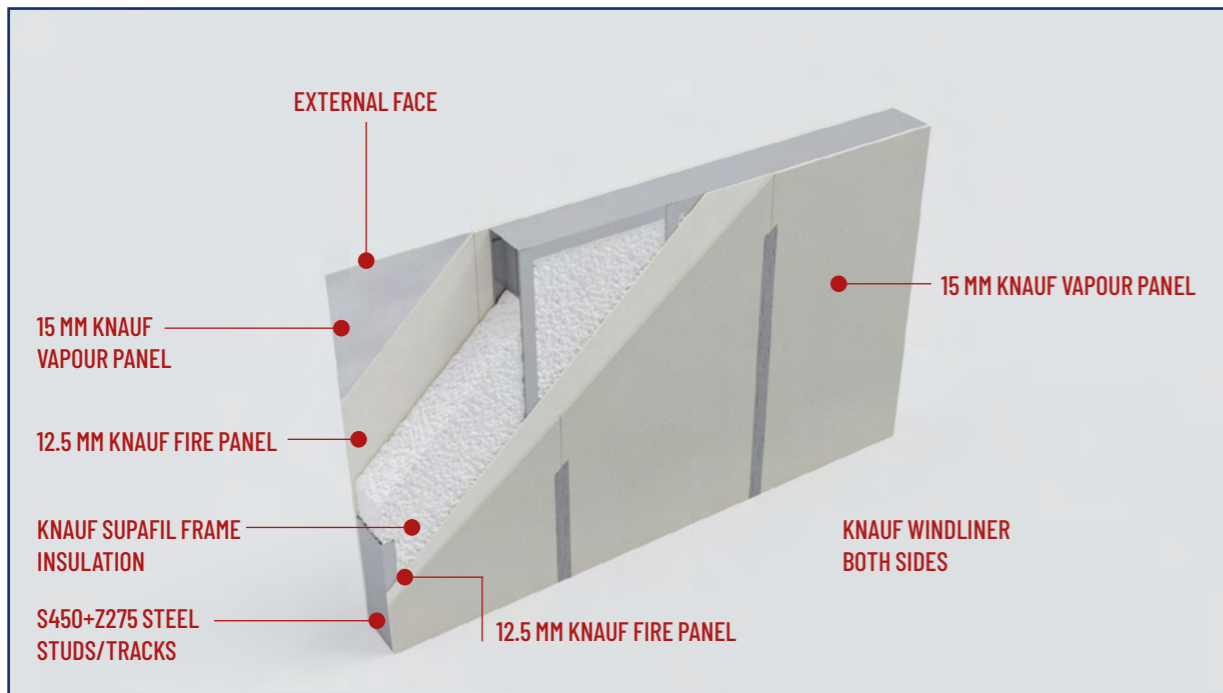

PRODUCT	Fire classification EI*	Airborne Sound Insulation (dB)*	U-Value (W/m2K)*	U-Value (W/m2K) With 50mm Rainscreen Slab	U-Value (W/m2K) With 100mm Rainscreen Slab
UNI WALL LB	90	48 (Expected)	/	/	/

The performance figures provided refer to UNI WALL loadbearing, excluding any finishes.

## UNI WALL LOADBEARING WITH PRE-CUT DOOR APERTURE

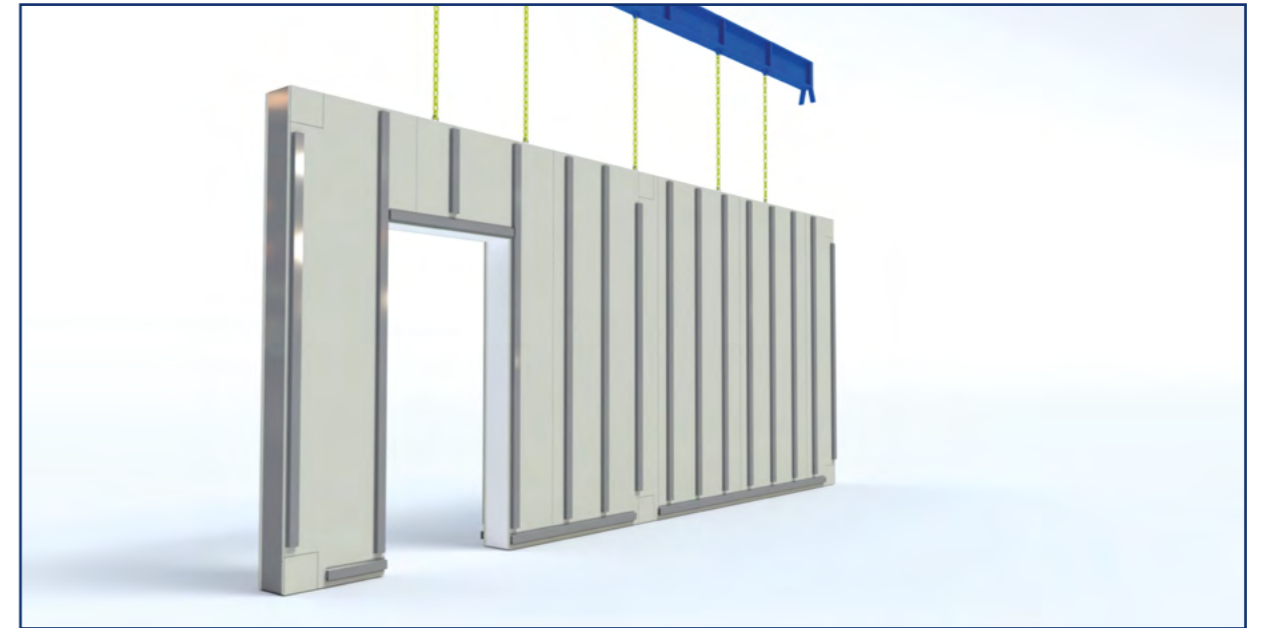

## UNI WALL LOADBEARING FULL BREAKDOWN

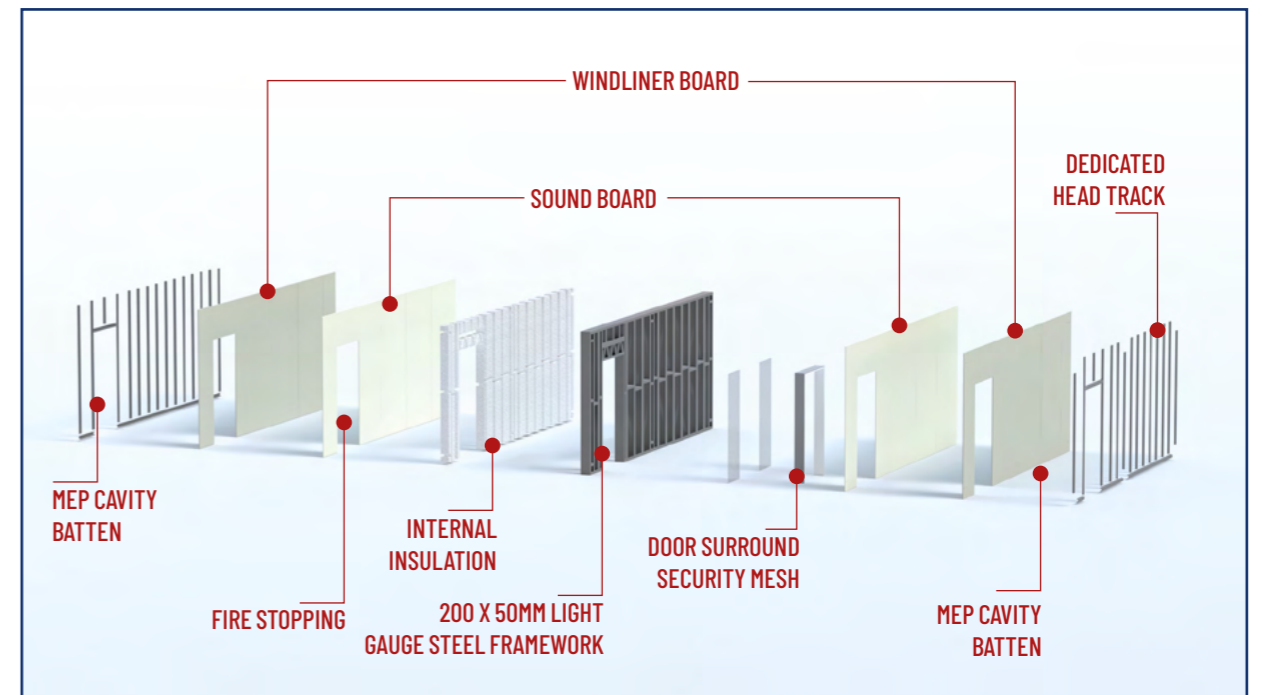

# UNISYSTEM<sup>LB</sup>

## LOADBEARING STANDARD SEQUENCING

**STAGE 1:** GROUND FLOOR INSTALLATION COMBINING UNIPANEL<sup>LB</sup>, UNIWALL<sup>LB</sup> AND UNIFLOOR.

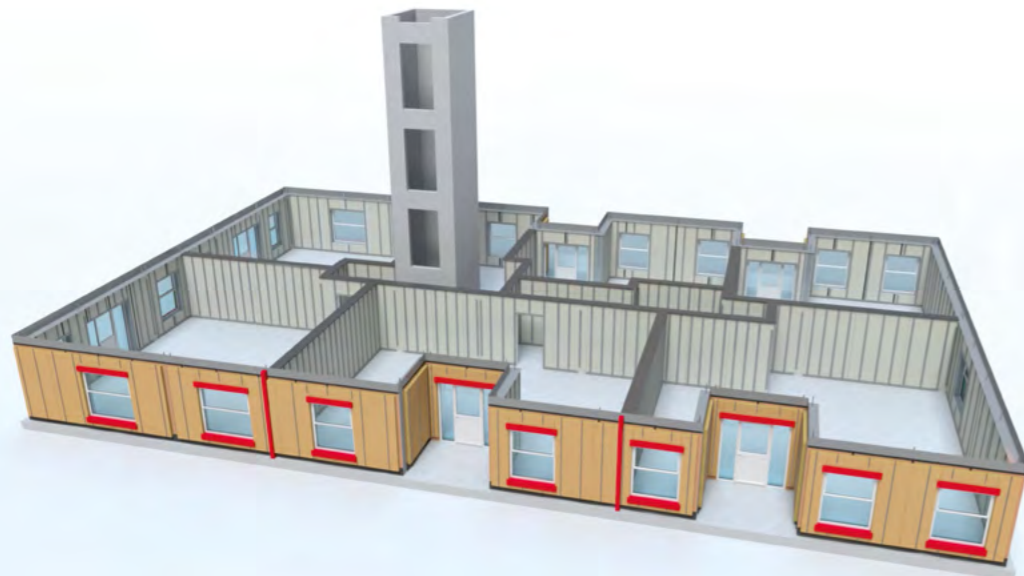

**STAGE 2:** UNIFLOOR OR COMPOSITE FLOOR IS LAID.



**STAGE 3:** BUILD UP OF MULTIPLE FLOORS UP TO SIX STOREYS, USING UNIPANEL<sup>LB</sup>, UNIWALL<sup>LB</sup> AND UNIFLOOR.



**STAGE 4:** BUILDING IS COMPLETED WITH A COMPATIBLE ROOF SYSTEM.



# FLOOR OPTIONS

**UNISYSTEM<sup>LB</sup> CAN INTEGRATE WITH A NUMBER OF MODERN FLOOR SYSTEMS AS WELL AS CONCRETE, STEEL OR TIMBER STAIRCASES AND UNIFLOOR.**

UNifloor is a versatile and cost effective floor cassette system specifically designed to seamlessly integrate with UNisystem<sup>LB</sup>. It is manufactured from the same robust light gauge steel profiles as our UNisystem<sup>LB</sup> then covered in durable OSB. This allows it to be insulated from below before final fix.

UNifloor can also be used as a roof cassette system. It provides a weatherproof element to a UNisystem<sup>LB</sup> building, either as a flat roof, in which instance it simply needs to be waterproofed and finished, or as a temporary roof prior to installation of a timber truss or modular roof.

it can be left in place as the attic floor and insulated from below before final fix.

**Technical UNifloor specifications**  
For technical specifications please see page 38 of this brochure.

**Composite floor profiles**  
UNisystem can also be integrated with a number of composite floor systems, the concrete providing improved thermal mass, as well superior acoustic, fire and structural performance where required.

# ROOF OPTIONS

**UNISYSTEM<sup>LB</sup> CAN INTEGRATED WITH A NUMBER OF MODERN ROOFING SYSTEMS:**

- Metal Profile Decking
- Timber Trusses
- Modular 'Smart' Roof
- Composite Roof Profiles
- UNiroof (coming soon)



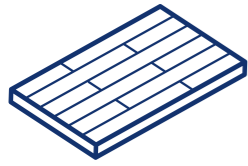

# UNIFLOOR

UNIFLOOR IS A LIGHT GAUGE STEEL FLOOR CASSETTE SYSTEM ADAPTABLE TO ANY SCALE.

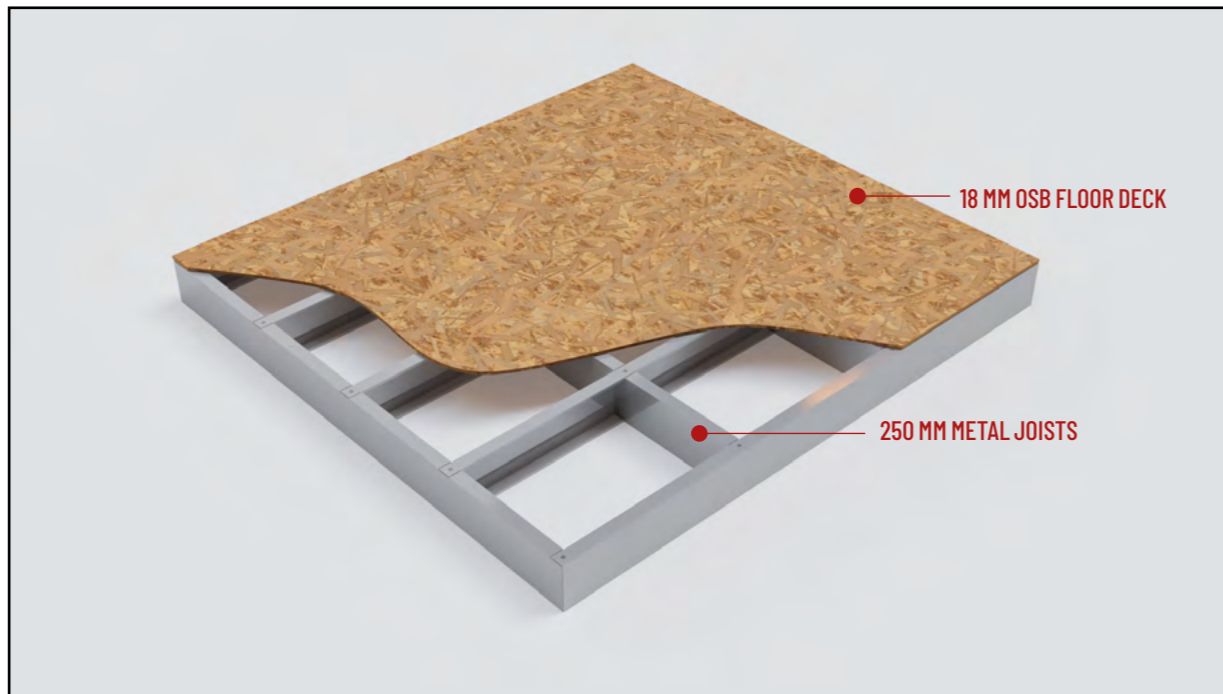

UNIFLOOR utilises 200x50x1.2 (in grade S450GD steel) vertical studs at maximum 600mm c/c, with closer centres as required for the design/loading. It can span up to 5 metres at 200mm increasing to 5.5m with the use of Frameclad 250mm deep flange joist.





MARKETING SUITE

HALCYON PLACE

Brentwood Central, Essex  
CGI is indicative only



# PRECISION INSTALLATION

UNISYSTEM INSTALLATION CAN BE UNDERTAKEN BY YOUR REINFORCED CONCRETE OR STEEL FRAME CONTRACTOR OR BY BRITISH OFFSITE. PANELS ARE MANUFACTURED AHEAD OF SITE REQUIREMENTS AND STORED SECURELY PENDING DELIVERY TO SITE.

Panels are lifted immediately into place from our purpose-made delivery vehicles and fixed into place via fixing brackets. These are screwed into the adjacent panel/structure with Ejoyt LS 5.5x50mm Tek screws or M10 x 60mm Excalibur Bolts, as required.

Panels over 5 metres in length are temporarily propped, in line with guidelines in the British Offsite installation manual. In instances where the UNipanel sits on a flat concrete slab, these are mechanically fixed to the concrete slab using 50=75mm angle brackets, and M6 Excalibur bolts at maximum 600 centres (100mm from ends). Props can be removed as soon as the reinforced concrete slab for the floor above has cured.

British Offsite provide complete installation guidelines to facilitate the installation of all products as well as lifting plans and RAMS.

# MEMBERSHIPS AND ACCREDITATIONS

## COMMITTED TO THE HIGHEST STANDARDS

WE'RE AN ACTIVE MEMBER OF SEVERAL INDUSTRY BODIES AND WORK WITH OUR INDUSTRY PARTNERS TO DRIVE INNOVATION AND STANDARDS FURTHER. WE'RE ALSO VERY PROUD OF THE MANY THIRD PARTY ACCREDITATIONS OUR PRODUCTS AND QUALITY SYSTEM HAVE ACHIEVED.

### Members of



### Accreditations



UKAS approved certification by Approachable of British Offsite's Quality Management System



Recognised for demonstrating exemplary levels of best practice in safety, efficiency and environmental protection across our fleet.



UKCA approved certification by SCCS of compliance with BS EN 1090-1:2009+A1:2011.



BRE certification in accordance with BS476 Part 22 (fire tests on building materials and structures), and EN 1364-1 (fire resistance tests for non-loadbearing elements – Part 1: Walls).



Stage 1 System Certification of UNisystem by the Steel Construction Institute, in accordance with NHBC standard Chapter 6.10 addressing durability, strength and stability.





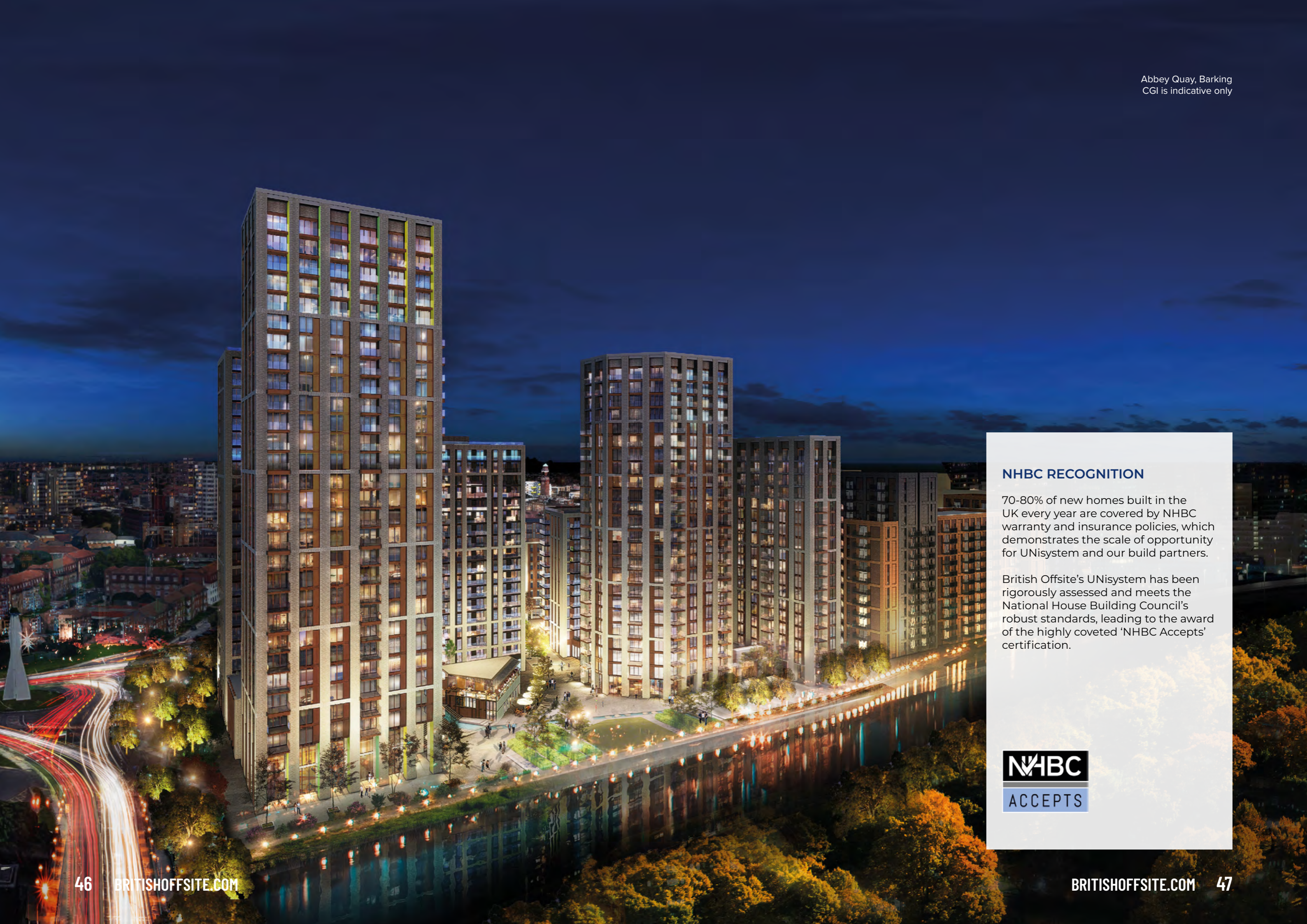

#### NHBC RECOGNITION

70-80% of new homes built in the UK every year are covered by NHBC warranty and insurance policies, which demonstrates the scale of opportunity for UNisystem and our build partners.

British Offsite's UNisystem has been rigorously assessed and meets the National House Building Council's robust standards, leading to the award of the highly coveted 'NHBC Accepts' certification.



# SUSTAINABILITY

## TARGETING NET ZERO CARBON

ACROSS OUR VALUE CHAIN – FROM PRODUCT DEVELOPMENT TO THE FINAL OPERATION OF BUILDINGS – WE’RE REDUCING ENERGY CONSUMPTION AND WASTE AND INCREASING OUR USE OF RECYCLED MATERIALS. WE CALL THIS OUR “FABRIC FIRST” APPROACH. IT RESULTS IN ENERGY EFFICIENT BUILDINGS THAT ARE MORE COST EFFECTIVE TO RUN AND HELP TO PROTECT THE PLANET.

Design of the Horizon factory with Randek UK focused on precision and efficiency, utilising state-of-the-art machinery with energy control measures built in.

Responsibly sourced steel for UNisystem’s core contains 38% recycled steel.

Solar panels on our Horizon factory roof generate renewable energy.

Just-in-time manufacturing methods lead to fewer deliveries to site, and with the work of up to five trades combined in one panel, road miles and energy consumption is reduced on projects.

The superior airtightness of UNisystem, due to precision manufacturing, increases building insulation and reduces energy consumption.

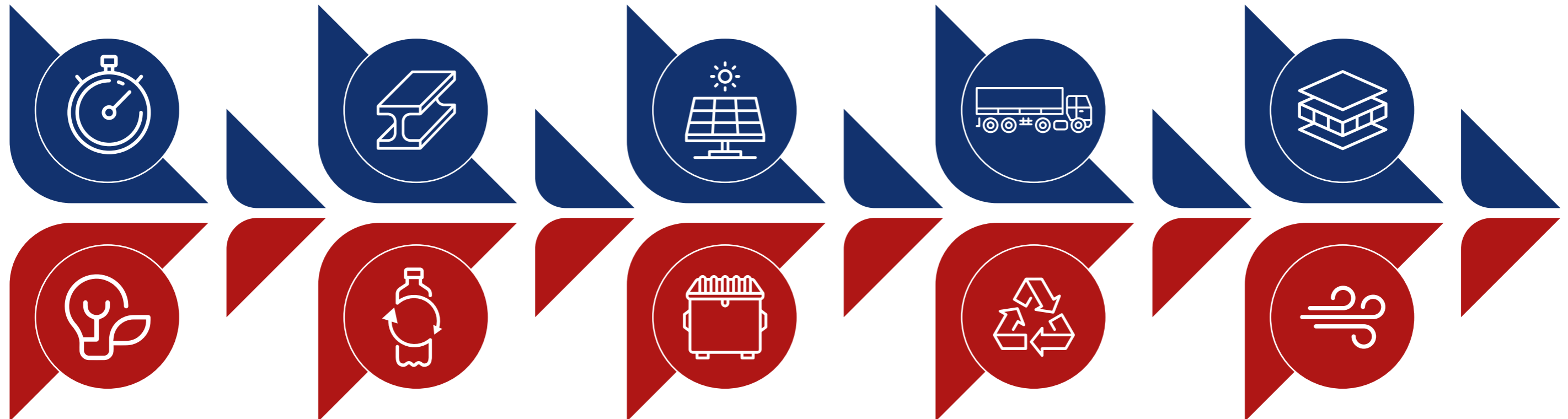

Continuous improvement of UNisystem and our BOS Fitout range, drives energy efficiency in the production and operation of buildings.

The insulation layer on UNipanel is made from recycled bottles.

Precision just-in-time manufacturing optimises the use of raw materials and reduces waste.

Durable 100% recycled packaging reduces the amount used and we ensure none goes to landfill.

Our panels come with the option of pre-installed glazed windows with exceptional airtightness, increasing the insulation of homes.

DEVELOPMENT

SOURCING

MANUFACTURING

LOGISTICS

PRODUCT

# TAILORMADE LOGISTICS

BRITISH OFFSITE'S IN-HOUSE LOGISTICS SERVICE IS A FURTHER MAJOR BENEFIT OF UTILISING UNISYSTEM FOR YOUR HOUSEBUILDING, MID-RISE OR HIGH-RISE PROJECT. WE HAVE COMPLETE CONTROL OVER THE SAFETY AND SECURITY OF PANELS AND MAINTAIN CLOSE CONTACT THROUGHOUT BUILD TO DELIVER PANELS TO YOUR SITE EXACTLY WHEN THEY'RE NEEDED.

We have our own fleet of vehicles which includes HGVs of different sizes and technical capabilities, so we can meet different needs. All vehicles are purpose-made to carry UNipanel, UNiwall and UNifloor safely and securely, whether to UK sites or overseas.

By managing our own fleet we have the flexibility to choose exactly the right HGV to carry specific lengths of panels, or a vehicle that is best suited for a particular site setting. For example, we have a rear-steering axle vehicle that's suitable for navigating constrained and busy urban settings, and a smaller, rigid vehicle that's appropriate for express deliveries.

All vehicles are fitted with real-time tracking, which enables our customer service team to provide accurate updates on progress, no matter where vehicles are in the UK or Europe, or even further afield. We offer one-to-one customer service, with our logistics team in direct conversation with programme and site managers long before build begins.



# WHERE TO FIND US



## British Offsite Head Office

**Horizon**  
1 Rontgen Place  
Horizon Boulevard  
Braintree  
Essex  
CM77 7AX

**Skyline**  
Skyline 120  
Avenue East  
Great Notley  
Braintree  
Essex  
CM77 7AL

☎ 01371 707270  
✉ [info@britishoffsite.com](mailto:info@britishoffsite.com)  
🌐 [britishoffsite.com](http://britishoffsite.com)



